

## Recording Time Chart

RDAC Grade	Sampling Frequency	Playback Range	RDAC Mode and Recording Time				
			H-LINEAR	LINEAR	MODE 3	MODE 2	MODE 1
S-HIGH	48 kHz	20Hz-22kHz	1:58:31	2:57:47	7:54:06	7:54:06	11:51:09
HIGH	44.1 kHz	20Hz-20kHz	2:08:57	3:13:26	8:53:49	8:53:49	12:53:44
STANDARD	32 kHz	20Hz-15kHz	2:57:47	4:26:41	11:51:09	11:51:09	17:46:44
LONG 1	22.05 kHz	20Hz-10kHz	4:17:54	6:26:52	17:31:39	17:31:39	25:47:28
LONG 2	16 kHz	20Hz-7.5kHz	5:55:34	8:53:22	23:42:18	23:42:18	35:33:28
ANNOUNCE	8 kHz	20Hz-3.7kHz	11:51:09	17:46:44	47:24:37	47:24:37	71:06:56

\* Mono Recording time per 1GB Memory Card (x 2 for AR-3000R)  
 \* Recording time is half for stereo recording  
 \* Time specs for continuous recording of 1 phrase

## AR-3000R Specifications

<b>Recording Format</b>	RDAC (Roland Digital Audio Coding)	<b>S/N Ratio</b>	90dB
<b>Recording Media</b>	Compact Flash Memory Card up to 2GB x 2	<b>Interfaces</b>	RS-232C, MIDI, AR-LINK
<b>RDAC Grade</b>	H-LINEAR, LINEAR, MODE3, MODE2, MODE1	<b>Power Supply</b>	AC 117, 230, 240V (50/60Hz)
<b>Phrase Type</b>	Stereo, Mono (Audio) or SMF (MIDI)	<b>Power Consumption</b>	11W (117V), 12W (230/240V)
<b>Number of Phrases</b>	Up to 2,000 phrases	<b>Dimensions &amp; Weight</b>	482(W) x 231.4(D) x 44(H) mm, 2.7kg
<b>Audio Input</b>	Mic Input : +46dBu/2k ohms/balanced Line Input : 0dBu/20k (stereo) or 10k (mono) ohms/unbalanced	<b>Accessories</b>	Rubber Feet, Card Protector (with screws), Owner's Manual, AC Cord
<b>Audio Output</b>	Line output : +4dBu/500 ohms/balanced, Mono output : +4dBu/500 ohms/unbalanced, Phone : 90+90mW Max (30 ohms or more)	<b>Options</b>	Network Card (AR-NT1R)

## AR-200R Specifications

<b>Recording Format</b>	RDAC (Roland Digital Audio Coding)	<b>Power Supply</b>	AC Adaptor or DC9 -24V
<b>Recording Media</b>	Compact Flash Memory Card up to 2GB	<b>Current Draw</b>	1000mA (AC Adaptor) or 1200mA (External DC Power)
<b>RDAC Grade</b>	H-LINEAR, LINEAR, MODE3, MODE2, MODE1	<b>Dimensions &amp; Weight</b>	218(W) x 234.7(D) x 44(H) mm, 1.4kg
<b>Phrase Type</b>	Stereo, Mono (Audio) or SMF (MIDI)	<b>Accessories</b>	Rubber Feet, Card Protector (with screws), Owner's Manual, AC adaptor
<b>Number of Phrases</b>	Up to 1,000 phrases *	<b>Options</b>	Rack Mount bracket
<b>Audio Input</b>	0dBu/10k ohms/unbalanced		
<b>Audio Output</b>	Line output : +4dBu/-10dBV/600 ohms/balanced Phone : 1+1 mW Max (30 ohms or more)		
<b>S/N Ratio</b>	84 dB		

\*When saved on AR-3000R

## AR-200S Specifications

<b>Recording Format</b>	RDAC (Roland Digital Audio Coding)	<b>Power Supply</b>	AC Adaptor or DC9 -24V
<b>Recording Media</b>	Compact Flash Memory Card up to 2GB	<b>Current Draw</b>	1000mA (AC Adaptor) or 1200mA (External DC Power)
<b>RDAC Grade</b>	H-LINEAR, LINEAR, MODE3, MODE2, MODE1	<b>Dimensions &amp; Weight</b>	218(W) x 233.3(D) x 44(H) mm, 1.5kg
<b>Phrase Type</b>	Stereo or Mono	<b>Accessories</b>	Rubber Feet, Card Protector (with screws), Euroblock Connector, Owner's Manual, AC adaptor
<b>Number of Phrases</b>	Up to 1,000 phrases	<b>Options</b>	Rack Mount bracket
<b>Audio Input</b>	-6dBu/10k ohms/balanced		
<b>Audio Output</b>	+4dBu/-10dBV/600 ohms/balanced		
<b>S/N Ratio</b>	84 dB		

## AR-3000R Dimension (mm)

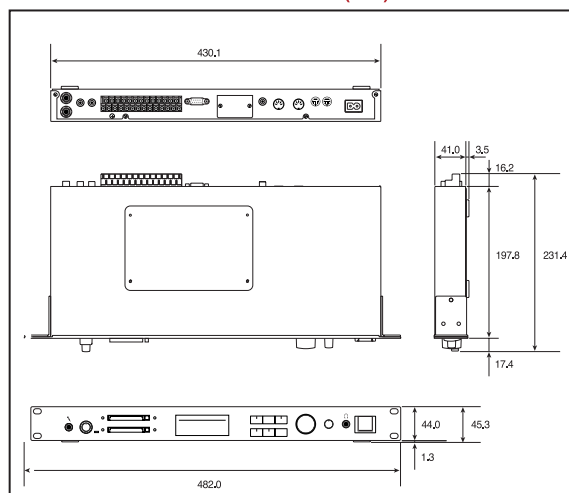

## AR-200R Dimension (mm)

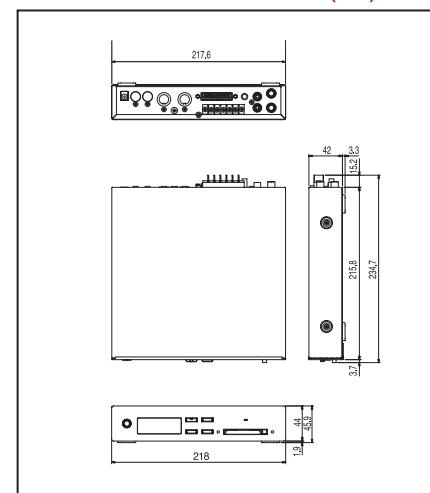

## AR-200S Dimension (mm)

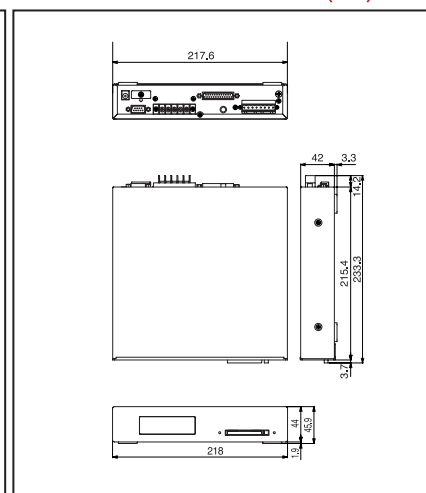

# The AR Series Audio Recorders AR-3000R AR-200R AR-200S



## The Industry Standard for Audio Playback

## No Moving Parts

The AR series is world renowned for its reliability. Audio is stored and played back from Compact Flash or other solid state memory, providing much more reliable performance than cassettes, CDs, DVDs, HDDs and other mechanical recording devices. Since audio or MIDI data is recorded directly to and played back from the memory card, the mechanical wear and tear and failure over time associated with rotating or winding media is completely eliminated.

## 24bit, 48kHz Linear Recording

The AR series' 24-bit, 48kHz audio sets the standard in audio quality for fixed installation applications. The AR series represents the industry standard in high quality audio with up to 48 kHz, 24 bit linear recording and playback. Users can select from a range of sample rates and recording times including the latest Roland Digital Audio Coding (RDAC) technology, which uses less memory with virtually no loss of sound quality and offers over 140 hours of recording time. For demanding applications up to 2,000 phrases can be stored on the AR-3000R.



# AR-3000R

Flagship AR product with a wide range of editing, playback and control features

## The industry standard for reliable, high quality audio playback

The AR-3000R Audio Recorder is a one rack space digital audio recorder/player designed for any application requiring high fidelity pre-recorded announcements. Theme parks, museums, elevators, airports, buses, trains and trams are just some of the installations that can benefit from the AR-3000R's high quality, over 140 hours of recording time.

## Easy integration with other systems

The AR-3000R can be synchronized with external devices using MTC and MMC. This enables the easy integration of up to 64 tracks of an AR system with external devices such as video presenters and show control devices.

## Link Multiple Units with Sample Accuracy

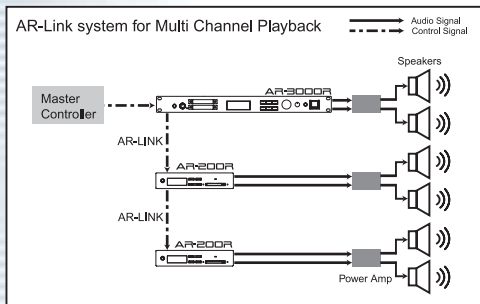

Using the AR-Link function, users can build a 64-track simultaneous playback system. One AR-3000R master device can lock up to 31 units of AR-3000R or AR-200R together for sample accurate playback.

## Recording and Playback of MIDI data

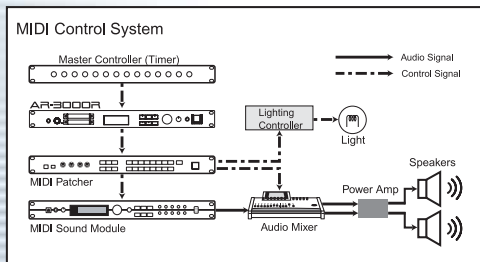

When used to record or play back MIDI data, the AR performs as a non-mechanical MIDI sequencer that can control or synchronize music or other event attractions such as lighting systems, effects or fountains.

## Flexible control options

The AR-3000R is the industry leader in flexible control options. Phrases can be played back using GPI control, RS-232C control, sophisticated internal playlists and many other options. It can also be triggered using manual front panel controls. There are also very useful phrase-based parameters like phrase level, fade in time, crossfade looping and more. Free ARE editing software makes it very easy to make playlists and import .WAV audio files.

## AR-NT1R Network option for AR-3000R

Using an installed AR-NT1R IP networking board a user can upload files and playlists, and remotely control an AR-3000R using any standard Ethernet network.

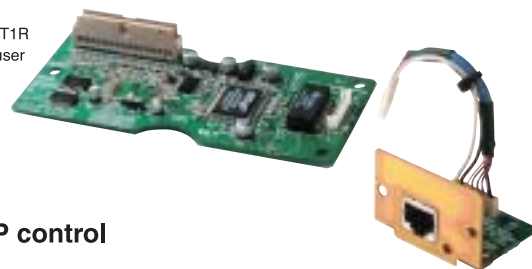

## Example of IP control

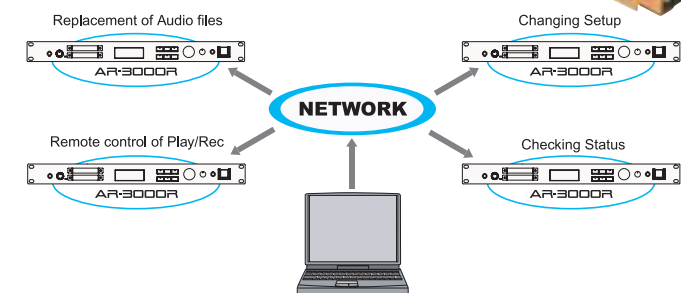

## Applications

Paging systems  
Museums  
Zoos  
Airports

Theme Parks  
Interactive installations  
Public Transportations

Radio cart replacement for instant on-air playback of jingles, spots and promos

Remotely controlled recorder for loading news highlights, stories

Interactive phone message playback

## AR-200R

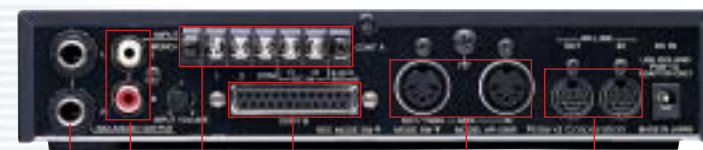

Line Input  
Audio Output  
Control/DC Power Inputs  
GP Input  
MIDI In/Out  
AR Link In/Out

## AR-200S



Euroblock Connector  
GPI Input  
Control/DC Power Inputs  
RS-232C

## Industry standard in sound quality and long recording times

The AR-200R/S Audio Recorder are half rack space digital audio recorder/players designed for any application requiring high fidelity pre-recorded announcements and control using RS-232C or GPI contact closures.

## The Industry Standard for extreme reliability

The AR series has set the industry standard for reliability for over 10 years. The AR-200R/S use solid state media for recording and playback eliminating failures due to mechanical movements found in CD and DVD players and guaranteeing no long term sound degradation.

## Easily integrate messages with external audio

External audio sources like FM broadcasts or CD playback can be connected to inputs on the AR's rear panel. The external audio will then be ducked to a user selectable level when a message is played by the AR.

## Multi-Channel Playback (AR-200R)

Using one AR-3000R as the master, multiple AR-200R units can be locked together for sample-accurate playback of up to 64 tracks. The system can also be synchronized to external show control using MTC or MMC.

## High quality audio with long recording times

The AR-200R/S support 16 bit/ 48kHz/linear recording as well as RDAC (Roland Digital Audio Coding) technology that offers very long recording times with virtually no loss of sound quality. Over 70 hours of audio can be recorded to the optional memory card.

## Installable anywhere

The AR-200R/S can be powered by AC or 9-24V DC. The compact size, rugged design, and power supply flexibility enables the installation of the AR-200R/S in just about any application environment.

## 100% prevention of accidental Play/Stop (AR-200S)

The AR-200S has no control buttons on the front panel. This prevents the accidental starting or stopping of audio phrase playback, allowing for a 100% secure installation.